

California Instruments Asterion AC Series

High Performance Programmable AC / DC Power Source

500 VA - 9000 VA
200 / 400 Vac
250 / 500 Vdc

Advanced Features

- High power density in 1U chassis, up to 1.5kVA
- Intuitive touch panel control
- Innovative iX2™ current doubling technology
- Multi-language display for global operation
- Auto paralleling for higher power
- Combine units for multiple phase configurations
- Complete avionic test suites (optional)
- ATE version available



Performance. Reliance. Brilliance.

Inspired by the enduring power of a brilliant star, the California Instruments Asterion line of AC power sources by AMETEK Programmable Power combines intelligence and flexibility to create an advanced platform of AC solutions. This easy-to-configure design features sophisticated technology for delivering high performance, programmable AC and DC power. Its sleek design packs maximum power density into a low-profile form factor with an intuitive touch screen interface placing that power at your fingertips. Centralized control and unparalleled modularity make Asterion the most adaptable platform on the market. Its groundbreaking capabilities set the standard for affordable, precision power sources.

Maximize rack space utilization with leading AC power density in a 1U chassis.

Employ full output power over widest voltage range with iX2™ technology.

Quickly and expertly control the AC source with intuitive touchscreen.

Control via Front Panel Touchscreen & Encoder or available digital control interfaces.

The Asterion AC Series is Digital Signal Processor (DSP) controlled and can be operated from the intuitive, easy to use front panel touchscreen or the Ethernet LXI, USB and RS232 standard control interfaces, as well as through the optional GPIB control interface.

The touchscreen function group icons include a Dashboard, Output Programming Parameters, Measurements, Sequencing, Configuration, Control Interfaces, Applications, and System Settings. Function selection and parameter entry can be achieved either by direct selection from the touchscreen or by using the encoder selector button. The control resolution is adjusted by a dynamic rate change algorithm that combines the benefits of precise control over small parameter changes with quick sweeps through the entire range.

Applications

The Asterion AC Series is designed for testing today’s complex electronics, including avionics, telecommunications and commercial electronics requiring low profile, light weight power sources with high power density. Other applications include:

- Commercial and military avionics test
- AC power simulation
- Manufacturing and process control
- Frequency & voltage conversion
- IEC standards testing
- ATE applications

Asterion Power Operating Area (per phase)

All Asterion sources employ AMETEK’s latest current enhancing technology, iX2™. iX2 current doubling technology enables output current to increase linearly up to two times the full voltage current as the voltage decreases from range maximum to one-half of range voltage. iX2 technology results in a source that delivers full power over the widest voltage ranges.

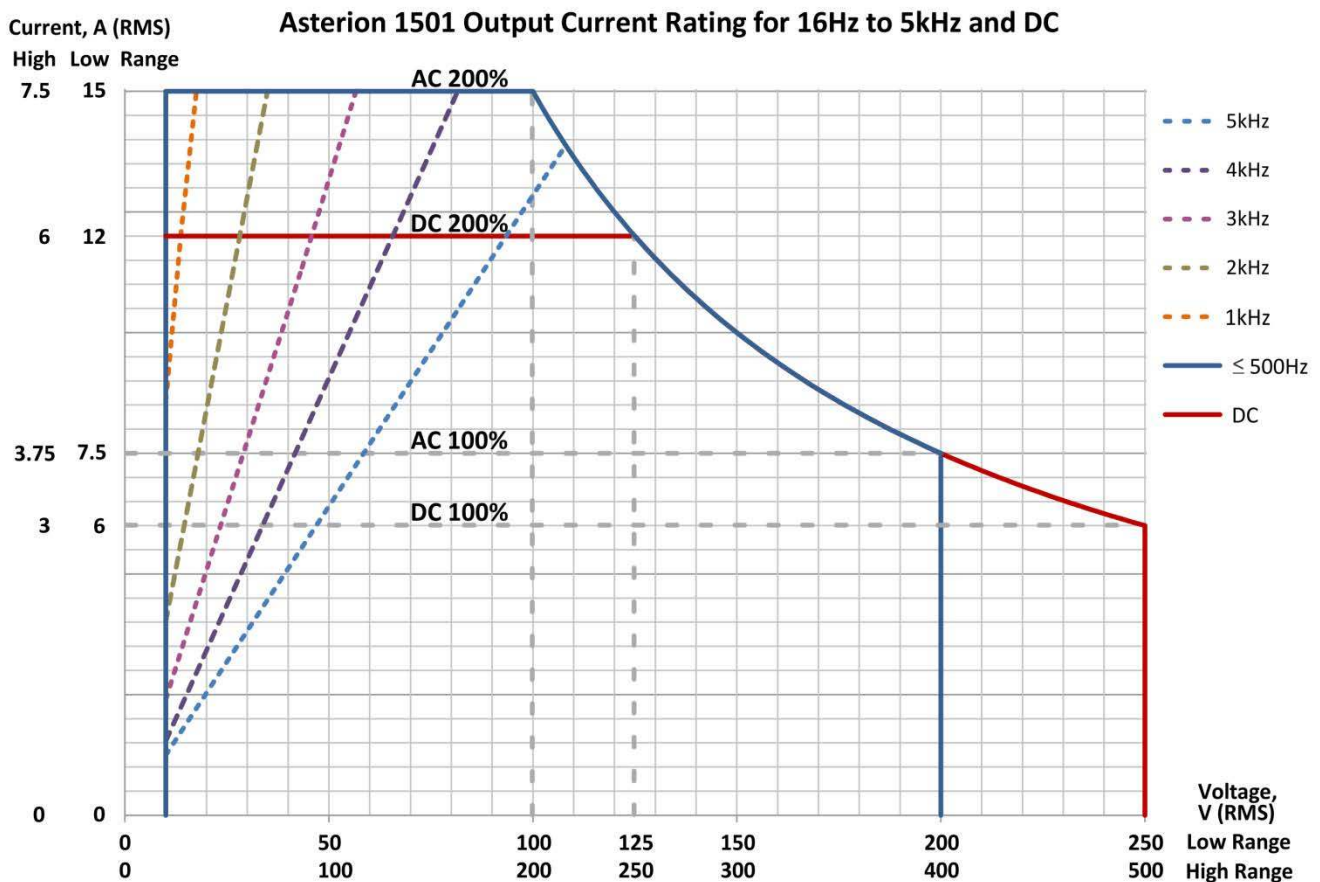

iX2™ Constant-Power: Output Current Versus Voltage, AST 1501

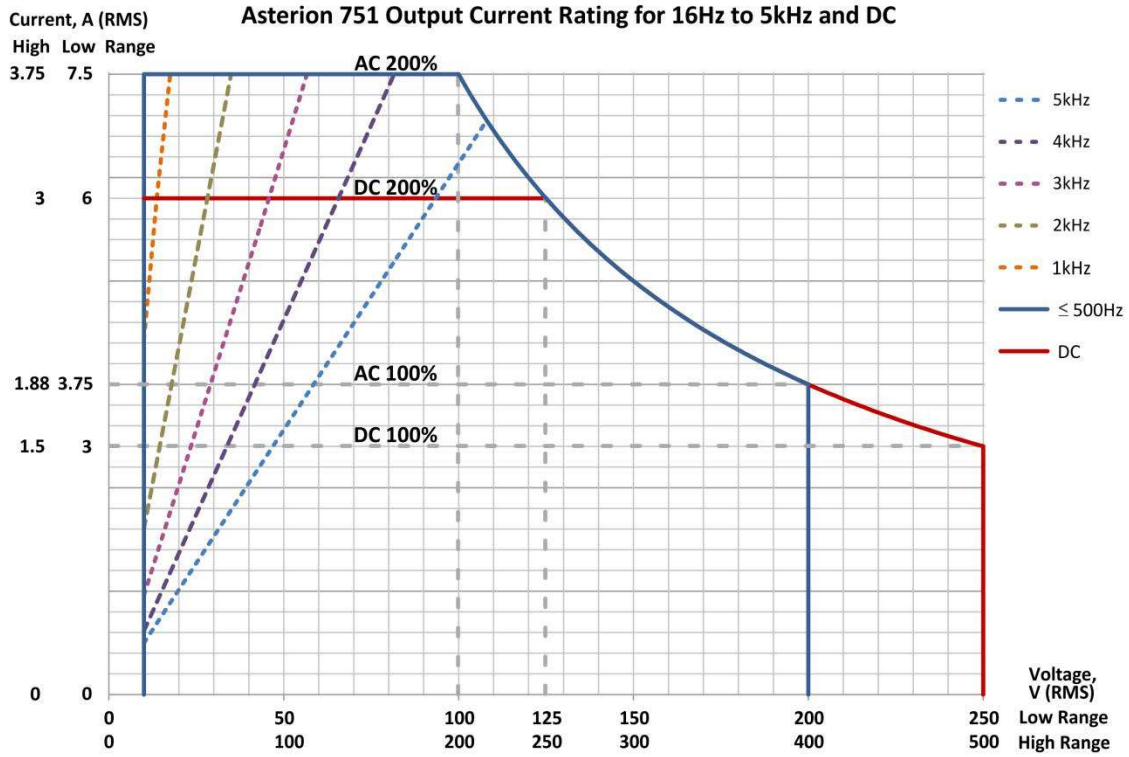

iX2™ Constant-Power: Output Current Versus Voltage, AST 751

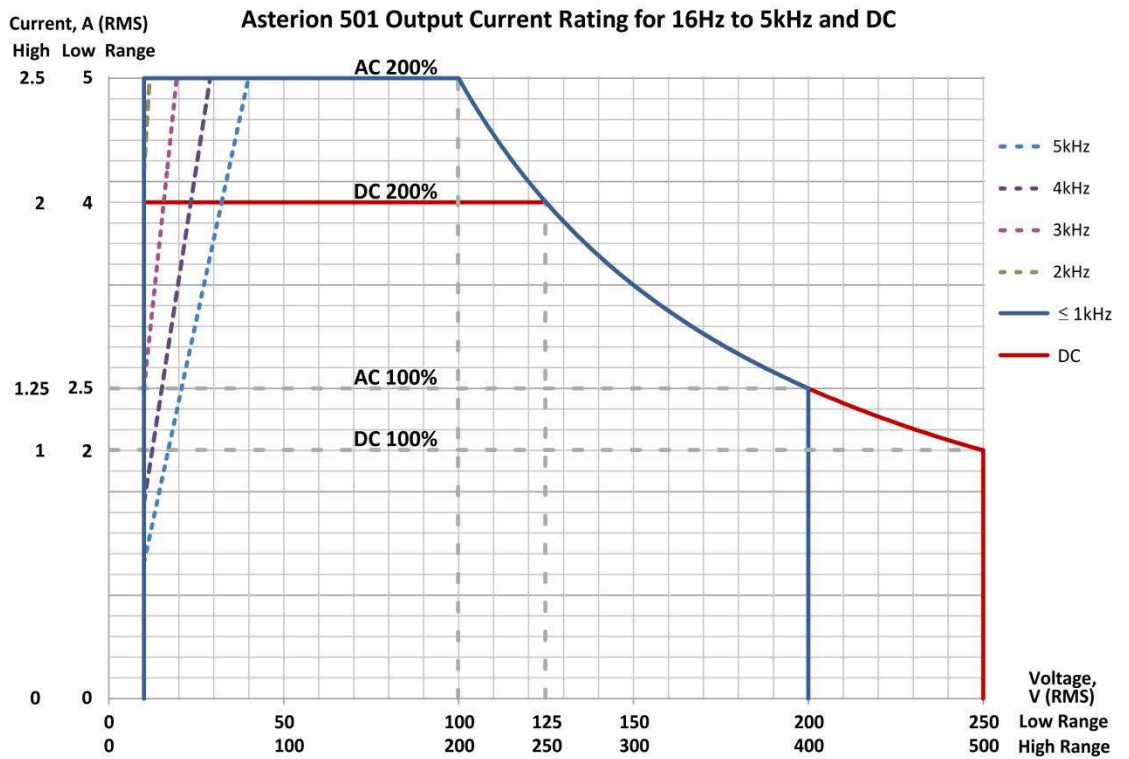

iX2™ Constant-Power: Output Current Versus Voltage, AST 501

Asterion AC Virtual Panels (Graphical User Interface)

Virtual Panels allow remote control of the Asterion AC power source as well as programming communication and monitoring for the Asterion ATE model without front panel display.

The screenshot displays the Asterion AC Virtual Panels GUI, which is organized into several functional areas:

- Settings:** Includes sections for Output Mode (AC, DC, AC+DC), Voltage Range (200.0, 400.0), Phase Mode (1-phase), and Overload Mode (Constant).
- Waveform Generation:** Features a Frequency (Hz) control set to 400.00 and a Phase A control with Amplitude (V) set to 115.00 and Phase A set to 115.
- Measurements Analysis:** Includes Remote Inhibit Level (HIGH, LOW) and Remote Inhibit Mode (LATC).
- IEC Tests:** A row of test buttons labeled 411, 413, 414, 417, 428, 429, 160, 704, A8D, 350, AMD, and 787.
- Avionics Tests:** A row of test buttons labeled 411, 413, 414, 417, 428, 429, 160, 704, A8D, 350, AMD, and 787.
- WaveForm Display:** Shows a graph of Voltage vs. Time (ms) with a blue waveform. A data table at the bottom provides key parameters:

V rms	V THD	I THD	I rms	ISF	Power	PF
115	2.3	2.3	4.36	2.2	350.98	0.7
- Acquisition Control:** Includes Offset (Mili Second) set to 2.00, Trigger Phase set to 0, and Sampling (Micro Second) set to 46.88.
- Transient List Editor:** A panel for configuring transient tests, including Phase Selection (Volt A, Volt B, Volt C), Type (VoltageStep, VoltageDrop, VoltageSurgeOrSag, FrequencySweep, FrequencyStep, VoltageFrequencyStep), and Execution Mode (Run: 1 Times).

Specifications

AC/DC Output Specifications			
Model	AST501	AST751	AST1501
Enclosure height	1U (44.45mm / 1.75in)	1U (44.45mm / 1.75in)	1U (44.45mm / 1.75in)
Output Phase	1-Phase (for multi-phase see note ¹)	1-Phase (for multi-phase see note ¹)	1-Phase (for multi-phase see note ¹)
Output Power; AC, AC+DC, & DC modes	500 VA / 500 W	750 VA / 750 W	1500 VA / 1500 W; with 1-PH AC input, derate output power from 1,500 W at 103.5 VAC to 1,300W at 90 VAC
AC and AC+ DC Voltage Ranges	Low-Range: 0 to 200 V(RMS); High-Range: 0 to 400 V(RMS)		
DC Output Voltage Ranges	Low-Range: 0 to 250 VDC; High-Range: 0 to 500 VDC		
Full Voltage AC and AC+DC RMS Output Current per phase	Low-Range: 2.5A at 200 VAC; High-Range: 1.25A at 400 VAC	Low-Range: 3.75A at 200 VAC; High-Range: 1.88A at 400 VAC	Low-Range: 7.5A at 200 VAC; High-Range: 3.75A at 400 VAC
iX2™ - Max RMS AC and AC+DC Output Current per phase	Low-Range: 5.0A up to 100VAC; High-Range: 2.5A up to 200 VAC	Low-Range: 7.5A up to 100VAC; High-Range: 3.75A up to 200 VAC	Low-Range: 15A up to 100VAC; High-Range: 7.5A up to 200 VAC
Full Voltage DC Output Current per phase	Low-Range: 2.0A at 250 VDC; High-Range: 1.0A at 500 VDC	Low-Range: 3.0A at 250 VDC; High-Range: 1.5A at 500 VDC	Low-Range: 6.0A at 250 VDC; High-Range: 3.0A at 500 VDC
iX2™ - Max DC Output Current per phase	Low-Range: 4.0A up to 125VDC; High-Range: 2.0A up to 250VDC	Low-Range: 6.0A up to 125VDC High-Range: 3.0A up to 250VDC	Low-Range: 12.0A up to 125VDC High-Range: 6.0A up to 250VDC
iX2™ - Constant Power Output	iX2 Current Doubling Technology allows for Constant-Power output capability in each output voltage range with full rated output power from 50% of full-scale output voltage to 100% of full-scale; the output current increases to 200% of rated current at 50% full-scale output voltage from 100% rated current at 100% of full-scale voltage. See Asterion Power Operating Area chart on page 2		
Voltage Accuracy	±(0.1% of actual + 0.2% of full-scale) for DC, and AC 16 Hz to 1 kHz; >1 kHz, add ±0.2% of full-scale/kHz; add ±0.1% of full scale for AC+DC mode. Valid in low-range from 5% of full-scale to 200 VAC(RMS)/250 VDC, and in high-range from 5% of full-scale to 400 VAC(RMS)/500 VDC; with sense leads connected.		
Voltage Stability, typical	±0.1% of full-scale over 8 hours; with constant line, load, and temperature; with sense leads connected		
Voltage Slew Rate, typical	≥10 V/μs with full-scale programmed voltage step		

AC/DC Output Specifications Continued	
Output Current Programming	Programmable from zero to 200% (iX2TM) of full-scale rating in each output range. Product of Voltage and Current cannot exceed power rating.
Output Current Programming Accuracy	$\pm(0.3\%$ of actual + 0.5% of maximum) for DC, and AC 16 Hz to 1 kHz; >1 kHz, add $\pm 0.3\%$ of maximum/kHz; add $\pm 0.1\%$ of full-scale for AC+DC mode. Valid from 5% of full-scale to 100% of full-scale
Line Regulation	$\pm 0.015\%$ of full-scale voltage, for a $\pm 10\%$ input line change; DC, or 40 Hz to 5 kHz.
Load Regulation	$\pm 0.025\%$ of full-scale voltage, for 100% of rated resistive load change; DC, or 40 Hz to 1 kHz, above 1 kHz, add $\pm 0.015\%$ of full-scale/kHz
Noise Level, typical	AC output: 450 mV(RMS), low-range; 750 mV(RMS), high-range; at ≥ 40 Hz output frequency; bandwidth, 20 kHz to 1 MHz; DC output: 400 mV(RMS), low-range; 700 mV(RMS), high-range; bandwidth, 20 Hz to 1 MHz.
Remote Sense	5 V(RMS), maximum total output lead drop
Crest Factor	5:1 of full-scale current in each output range (ratio of peak output current to RMS full-scale output current)
Output Power Factor	0, lagging to 0, leading
Frequency, (-LF and -HF options)	Standard models: DC, and 16 Hz to 1 kHz; -LF option: DC, and 16 Hz to 550 Hz; -HF option; DC, and 16 Hz to 5 kHz.
Frequency Accuracy, (-FC option)	Standard models: $\pm(0.01\%$ of actual + frequency resolution/2) -FC option: $\pm 0.25\%$
Frequency Resolution (without Clock/Lock option enabled)	0.01 Hz resolution, 16-81.91 Hz; 0.1 Hz resolution, 82-819.1 Hz ; 1 Hz resolution, 820-5000 Hz
Frequency Temperature Coefficient, typical	10 ppm/ $^{\circ}$ C of full-scale range
Phase Programming Range	0.0 $^{\circ}$ to 360.0 $^{\circ}$, relative external synchronization signal or Lock signal
Phase Accuracy	$\pm 1^{\circ}$, 16 Hz to 100 Hz; $\pm 2^{\circ}$ >100 Hz to 1 kHz, plus $\pm 1^{\circ}$ /kHz above 1 kHz
¹ Multi phase systems can be created using multiple chassis (up to 6 phases supported)	

AC Input Specifications			
Model	AST501	AST751	AST1501
Input Voltage, Nominal Rating	100-240 VAC	100-240 VAC	100-240 VAC
Input Voltage, Operating Range	90-264 VAC	90-264 VAC	90-264 VAC; with 1-PH AC input, derate output power from 1,500 W at 103.5 VAC to 1,300W at 90 VAC
Input Frequency	50 Hz, 60 Hz, 400 Hz	50 Hz, 60 Hz, 400 Hz	50 Hz, 60 Hz, 400 Hz
Input Frequency Range	47-440 Hz	47-440 Hz	47-440 Hz
Input Current, maximum with 1-PH input	7.6 A (RMS) at 90 VAC	11 A (RMS) at 90 VAC	20 A (RMS) at 90 VAC to 103.5 VAC
Input Current, maximum with 3-PH input	4.4 A(RMS) at 90 VAC, line-to line	6.5 A(RMS) at 90 VAC, line-to line	13 A(RMS) at 90 VAC, line-to line
Efficiency ¹ , typical	69%	72%	75%
Power Factor ² , typical	0.98; active PFC	0.98; active PFC	0.98; active PFC
Hold-Up Time ³ , typical	≥10 ms	≥10 ms	≥10 ms
Inrush Current, typical	30 A (PK) at 264 VAC	30 A (PK) at 264 VAC	30 A (PK) at 264 VAC
1-PH Input	2 wire + ground		
3-PH Input	3-wire + ground; delta configuration		
Isolation Voltage	2200 VAC, input to output; 1350 VAC, input to chassis		
¹ At full load and DC or 16 Hz to 1 kHz output frequency, with AC input voltage of 115 V(RMS) or 230 V(RMS), and 50/60 Hz input frequency			
² At full load, with 1-phase AC input voltage of 115 V(RMS) or 230 V(RMS), and 50/60 Hz input frequency			
³ At full load and with AC input voltage of 115 V(RMS) or 230 V(RMS)			

AC Output Measurement	
Parameter	Specification ¹
Voltage Range	AC and AC+DC output: 0-500 V(RMS)
Voltage Accuracy	$\pm(0.1\%$ of actual + 0.2% of full-scale) for AC 16 Hz to 1 kHz; >1 kHz, add $\pm 0.2\%$ of full-scale/kHz; add $\pm 0.1\%$ of full-scale for AC+DC mode. Valid in low-range from 5% of full-scale to 200 VAC(RMS), and in high-range from 5% of full-scale to 400 VAC(RMS); with sense leads connected.
Current Range	0-200% of full-scale output current
Current Accuracy	$\pm(0.3\%$ of actual + 0.5% of maximum) for AC 16 Hz to 1 kHz; >1 kHz, add $\pm 0.3\%$ of maximum/kHz; add $\pm 0.1\%$ of full-scale for AC+DC mode. Valid from 5% of full-scale to 100% of full-scale.
Peak Current Range	0-500% of full-scale output current
Peak Current Accuracy	$\pm(0.5\%$ of actual 0.5% of maximum) for AC 16 Hz to 1 kHz; >1 kHz, add $\pm 0.3\%$ of maximum/kHz; add $\pm 0.1\%$ of full-scale for AC+DC mode. Valid from 5% of full-scale to 100% of full-scale.
Frequency Range	16 Hz to 5.0 kHz
Frequency Accuracy	$\pm(0.01\%$ of actual + frequency resolution/2)
Phase Range	0-360°
Phase Accuracy	$\pm 1^\circ$, 16 Hz to 100 Hz; $\pm 2^\circ$, >100 Hz to 1 kHz; $\pm 5^\circ$, >1 kHz
Real Power Range, Full-Scale	Output power rating of model.
Real Power Accuracy	$\pm(0.4\%$ of actual + 0.7% of full-scale) for AC 16 Hz to 1 kHz; >1 kHz, add $\pm 0.4\%$ of full-scale/kHz; add $\pm 0.2\%$ of full-scale for AC+DC mode.
Apparent Power, Full-Scale	Output power rating of model.
Apparent Power Accuracy	$\pm(0.4\%$ of actual + 0.7% of full-scale) for AC 16 Hz to 1 kHz; >1 kHz, add $\pm 0.4\%$ of full-scale/kHz; add $\pm 0.2\%$ of full-scale for AC+DC mode.
Power Factor Range	0-1
Power Factor Accuracy	$\pm 2\%$ of full-scale
¹ Accuracy specifications apply above 100 counts of resolution; for multi-chassis configurations, multiply the output current and power, and the accuracy specifications, by the number of chassis; power factor accuracy applies for PF > 0.5 and output apparent power > 50% of maximum rating; frequency measurement specifications valid for output voltage >5% of full-scale.	

DC Output Measurement	
Parameter	Specification ¹
Voltage Range	±500 VDC
Voltage Accuracy	±(0.1% of actual + 0.2% of full-scale); valid in low-range from 5% of full-scale to 250 VDC, and in high-range from 5% of full-scale to 500 VDC; with sense leads connected.
Current Range, Maximum	0-200% of full-scale output
Current Accuracy	±(0.3% of actual + 0.5% of maximum); valid from 5% of full-scale to 100% of full-scale.
Power Range, Full-Scale	Output power rating of model.
Power Accuracy	±(0.4% of actual + 0.7% of full-scale)

¹Accuracy specifications apply above 100 counts of resolution; for multi-chassis configurations, multiply the output current and power, and the accuracy specifications, by the number of chassis.

Harmonic Measurement	
Parameter	Specification
Frequency, Fundamental	16-81.91 Hz, 82.0-819.1 Hz, 820-960 Hz
Harmonic Frequency	32 Hz to 48 kHz; 2nd to 50th harmonic
Fundamental Voltage Accuracy	±(0.2% of actual + 0.3% of full-scale) for 16 Hz to 960 Hz.
Harmonic Voltage Accuracy	±(0.2% of actual + 0.3% of full-scale + 0.3% of full-scale/kHz).
Fundamental Current Accuracy	±(0.4% of actual + 0.6% of maximum) for 16 Hz to 960 Hz.
Harmonic Current Accuracy	±(0.4% of actual + 0.6% of maximum + 0.4% of maximum/kHz).

Protection Functions
Output Overvoltage Protection (OVP); Output Current Limit Protection; Output Short-Circuit Protection; AC Input Overcurrent Protection; AC Input Under voltage Protection; AC Input Transient Protection; Over temperature Protection (OTP)

Environmental	
Parameter	Specification
Operating Temperature	0°C to 40°C (32° to 104° F)
Storage Temperature	-40°C to 85°C (-40°F to 185° F)
Altitude	2000 m (6,562 ft)
Relative Humidity	5-95 %, non-condensing
Vibration	MIL-PRF-28800F, Class 3; 5-500 Hz per Paragraph 4.5.5.3.1.
Shock	MIL-PRF-28800F, Class 3; 30G half-sine with 11ms duration per Paragraph 4.5.5.4.1.
Transportation Integrity	ISTA Test Procedure 1A

Mechanical	
Parameter	Specification
Dimensions	1U chassis: H, 1.75" (44.45 mm); W (front panel), 19.0" (483mm); D, 23.0" (584mm); 1U chassis: H, 1.75" (44.45 mm); W (chassis), 16.9" (483mm); D, 23.0" (584mm);
Unit Weight	AST 501/751: 19 lb / 8.6 kg; AST 1501: 22 lb / 10 kg.
Shipping Weight	AST 501/751: 29 lb / 63.8kg; AST 1501: 32 lb / 70.4 kg.
Cooling	Force-air cooling; linear, variable fan speed control; air intake at front/sides and exhaust at rear

Regulatory Compliance	
Parameter	Specification
EMC	CE marked for EMC Directive 89/336/EEC per EN61326-1:2013, Class-A for emissions and immunity standard as required for the EU CE Mark.
Safety	CSA NRTL certified for US and Canada to CAN/CSA-C22.2 No. 61010-1-12, UL 61010-1 Third Edition. CE marked for LVD compliance 2006/95/EC to EN 61010-1 third edition as required for the EU CE mark.
CE Mark LVD Categories	Installation Overvoltage Category: II; Pollution Degree: 2; Class II equipment; indoor use only.
RoHS	CE marked for Compliance with EU Directive 2011/65/EU for Restriction of Hazardous Substances in Electrical and Electronic Equipment.

Operational Characteristics	
Parameter	Characteristic
Parallel and Multi-Phase Operation	Multi-chassis configurations can easily be formed with up to six paralleled units (up to 9000VA) per phase and multi-phase (e.g. 3-phase) groups of up to six phases using one master unit and up to five units operating as auxiliary units per phase. Parallel chassis configuration is automatically accomplished when the chassis are interconnected with the interface cables, and requires no user setup, except to wire the AC inputs and outputs appropriately. Multi-Phase chassis configurations require LKM/LKS options.
Output Relays	Isolation and range relays are provided internally to automatically configure the outputs, turn the output on/off, and disconnect the load from the output amplifier when in the off state.
Transient Generator	Output can be controlled to produce transient events with 500 μ s programming resolution: Voltage: drop, step, sag, surge, sweep; Frequency: step, sag, surge, sweep; Voltage and Frequency: step, sweep.
Clock and Lock Mode, (Options, -LKM and -LKS required)	Multi-phase configurations can be formed with up to six units using the CLOCK and LOCK signal interface. One unit acts as the master and provides the reference clock to the other auxiliary units.
Calibration	Firmware-based calibration through the digital interface, GUI, or front panel display.
XLOAD Output Characteristic	User-selectable XLOAD mode operation provides revised regulation characteristics for additional stability margins when driving large capacitive loads.
Automatic Level Control (ALC)	ALC operation enables a digitally implemented feedback control loop to provide precise regulation of the RMS value of the output parameter.
-HF, option	High frequency option: upper limit is 5 kHz for a range of 16 Hz to 5 kHz
-LF, option	Low frequency option: upper limit is 550 Hz for a range of 16 Hz to 550 Hz
-FC, option	Reduced frequency control option: $\pm 0.25\%$ accuracy of output frequency
-LKM and -LKS, options (Clock and Lock Mode)	Multi-phase configurations can be formed with up to six units using the Clock and Lock signal interface. One unit acts as the master and provides the reference signals to the other auxiliary units.
-LKM, option	Clock and Lock interface option, master unit
-LKS, option	Clock and Lock interface option, auxiliary
-MB, option	Multi-Chassis option: provides full feature Enhanced controllers in auxiliary units of multi-chassis system configurations.

Front Panel Options	
Option	Description
Enhanced	Touch-Panel, TFT color LCD display with menu-based control;
ATE	No front-panel display; only status indicators;

Firmware / Software Options	
Option ¹	Description
B787	Avionics Electrical Power Quality Test Software - Boeing 787B3-0147 A/B/C (B787)
AMD	Avionics Electrical Power Quality Test Software - Airbus AMD24 C (A400M)
AVSTD	Avionics Electrical Power Quality Test Software Package - includes 160 (RTCA/DO160 E/F/G), 704 (MIL-STD 704 A/B/C/D/E/F), ABD (Airbus ADB100.1.8 D/E), A350 (Airbus ADB100.1.8.1 B/C)
AVALL	Avionics Electrical Power Quality Test Software Package - includes AVSTD, B787, AMD
- 411	IEC 61000-4-11 EMC test firmware for pre-compliance testing.
- 413	IEC 61000-4-13 Harmonics and Inter-harmonics EMC test firmware.
¹ For Avionics Options reference the Avionics Software Manual (P/N 4994-971) for test details; All options require use of the Virtual Panels Graphical User Interface Windows application software provided (reference CD ROM CIC496).	

Remote Control Input / Output Signal Characteristics	
Function	Characteristics
External Signal – Waveform input	Signal input for output voltage waveform programming by external analog reference
External Gain Control - Analog Programming of Output Voltage Amplitude	Signal voltage input to set the voltage amplitude of a waveform that is set by internal controller reference;
External Modulation – Analog Modulation of Output Voltage Amplitude	Signal input for output voltage modulation of waveform set by internal controller reference;
Trigger Output	Signal output with dual function: user-selectable as either function trigger or list trigger; pulse duration, 400 μ s.
Output Voltage Monitors	Signal output for monitoring the waveform of the command signal of the output amplifier; 0 -5 V(RMS) signal range for zero to full-scale output voltage;
Trigger Input	Signal input for external trigger for execution of programmed value.
Synchronization Clock	Signal input for external square wave clock to control the output frequency and phase of the waveform generated by the internal generator;
Remote Inhibit	Signal input to turn the output on/off.
Fault Output	Signal output indicating that a fault condition is present; solid-state, normally-closed ac/dc switch;
LKM (Option)	Signal outputs for Master Clock and Logic signals used in synchronizing two or more AC sources
LKS (Option)	Signal inputs for Auxiliary Clock and Logic signals used in synchronizing two or more AC sources

Chassis Dimension Drawings

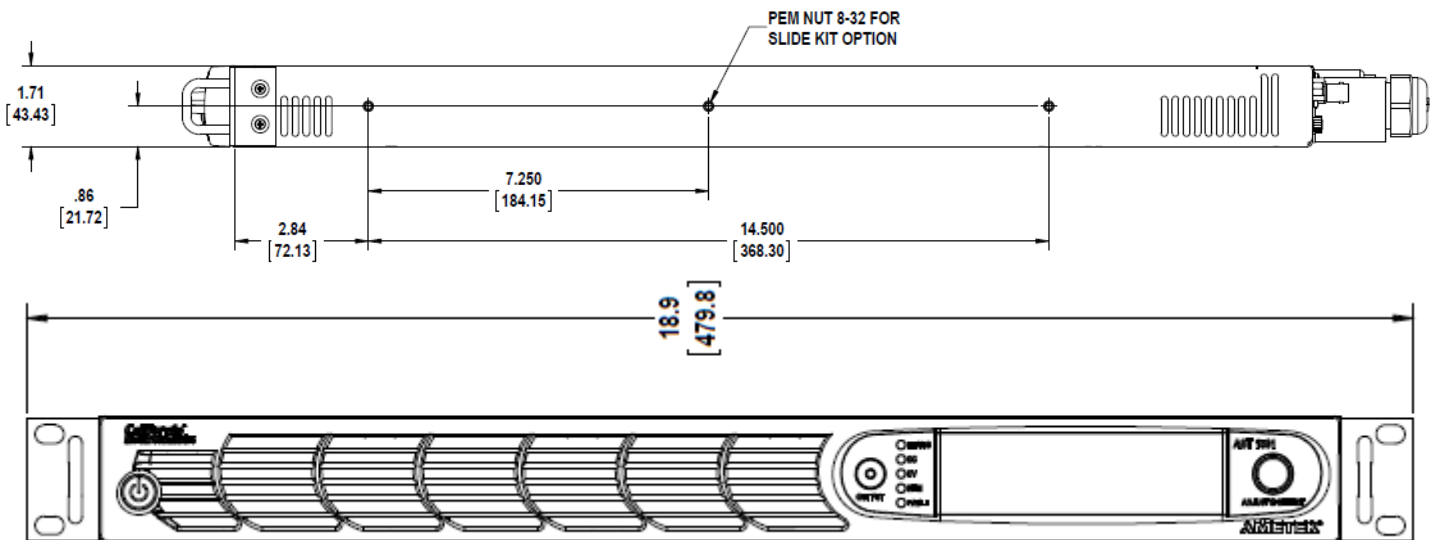
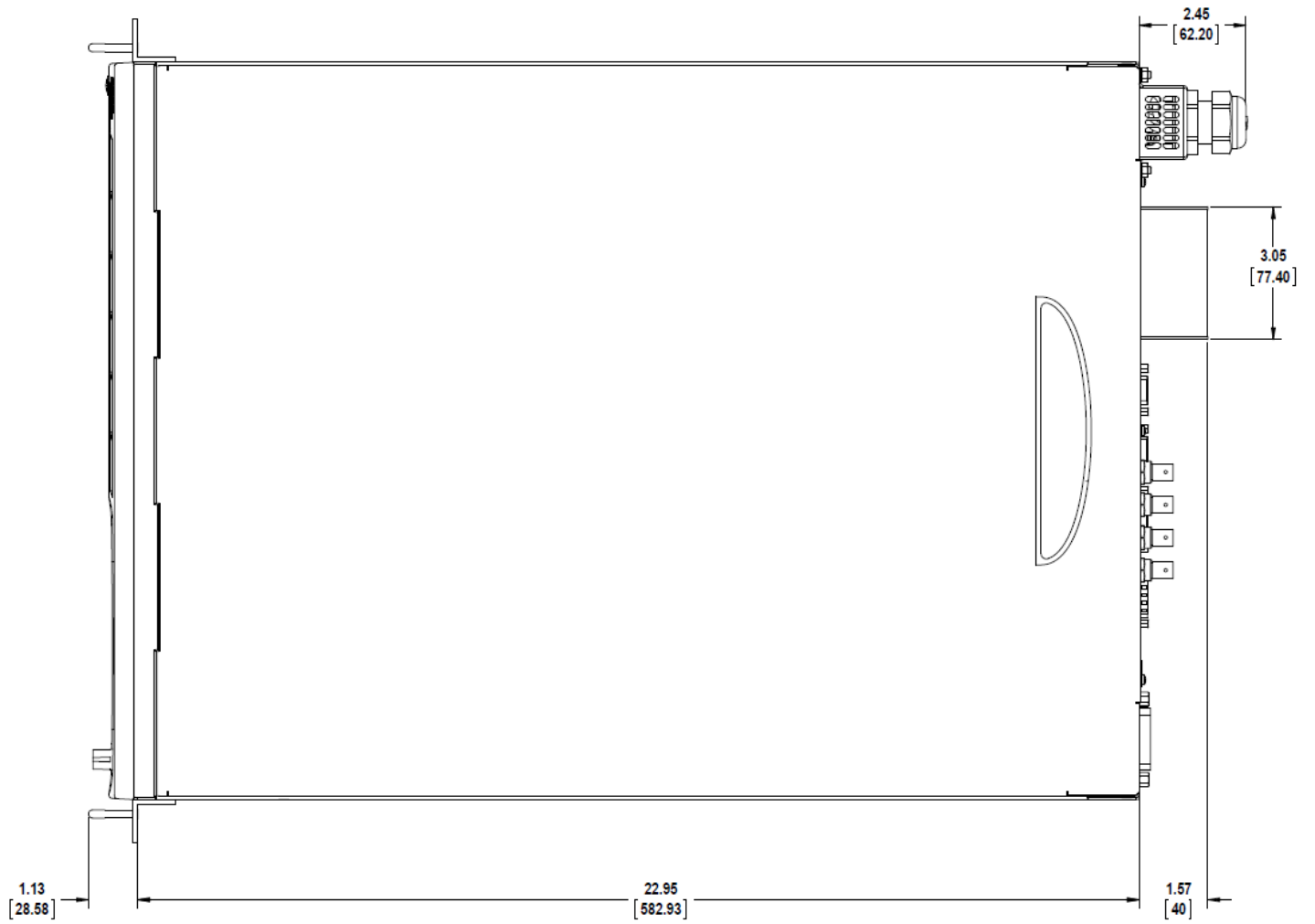

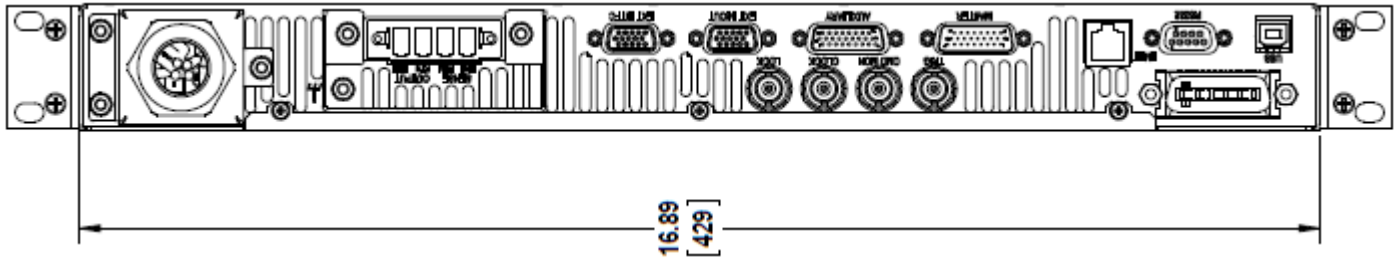

Options & Order Information

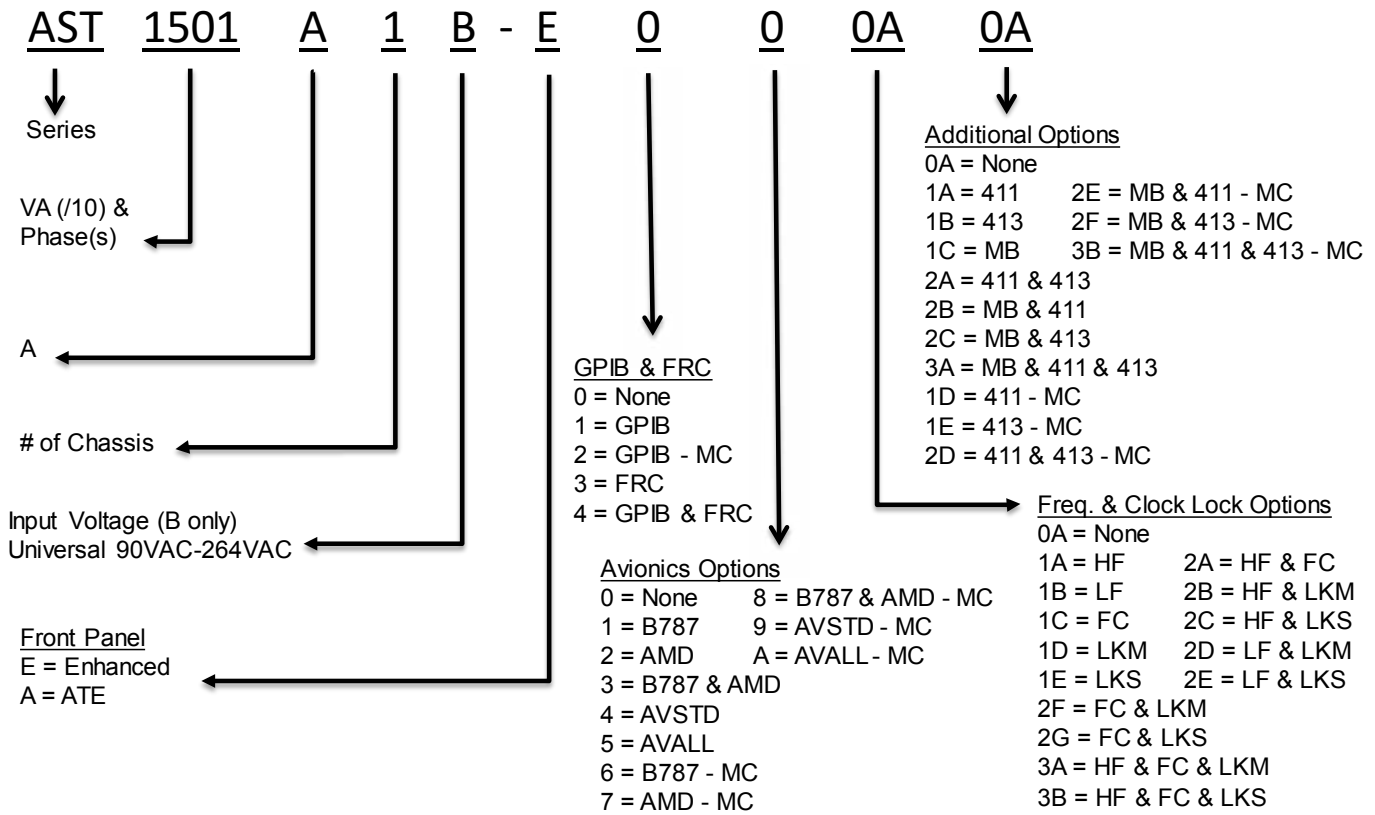

Example Model Numbers:

Model Number	Power Level (VA/W)	Output Phases	Place Holder	# of chassis	Input Power	Front Panel	GPIB	Avionics Options	Frequency & Clock Lock Options	Other Options
AST0501A1B-A010A1A	500	1	A	1	Universal 90-264VAC	ATE	No	B787	None	411
AST0751A1B-E021A1B	750	1	A	1	Universal 90-264VAC	Enhanced	No	AMD	HF	413
AST1501A1B-A131D2A	1500	1	A	1	Universal 90-264VAC	ATE	Yes	B787 & AMD	LKM	411 & 413
AST1001A2B-E041B0A	1000	1	A	2	Universal 90-264VAC	Enhanced	No	AVSTD	LF	None
AST1002A2B-A001A0A	1000	2	A	2	Universal 90-264VAC	ATE	No	None/NA	HF	None
AST1502A2B-E000A0A	1500	2	A	2	Universal 90-264VAC	Enhanced	No	None/NA	None	None
AST3001A2B-E0A2A0A	3000	1	A	2	Universal 90-264VAC	Enhanced	No	AVALL - MC	HF & FC	None
AST3002A2B-E000A0A	3000	2	A	2	Universal 90-264VAC	Enhanced	No	None/NA	None	None
AST1503A3B-E042A1C	1500	3	A	3	Universal 90-264VAC	Enhanced	No	None/NA	HF & FC	MB
AST2251A3B-E101A0A	2250	1	A	3	Universal 90-264VAC	Enhanced	Yes	None	HF	None
AST2253A3B-E000A3A	2250	3	A	3	Universal 90-264VAC	Enhanced	No	None/NA	None	MB & 411 & 413
AST4501A3B-E090A0A	4500	1	A	3	Universal 90-264VAC	Enhanced	No	AVSTD - MC	None	None
AST4503A3B-E031B3B	4500	3	A	3	Universal 90-264VAC	Enhanced	No	None/NA	LF	MB & 411 & 413 - MC

Options and model descriptions:

Base Models	# of chassis	Phase(s) Out	Description	Size
AST0501A1	1	1	Programmable 500VA, Single Phase, Dual Voltage Range	1U
AST0751A1	1	1	Programmable 750VA, Single Phase, Dual Voltage Range	1U
AST1501A1	1	1	Programmable 1500VA, Single Phase, Dual Voltage Range	1U
Multi-Chassis (MC) Packages	# of chassis	Phase(s) Out	Description	Size
AST1001A2 ^{1,2}	2	1	Programmable 1000VA, 1 Phase (includes two AST0501A1)	2U
AST3001A2 ^{1,2}	2	1	Programmable 3000VA, 1 Phase (includes two AST1501A1)	2U
AST2251A3 ^{1,2}	3	1	Programmable 2250VA, 1 Phase (includes three AST0751A1)	3U
AST4501A3 ^{1,2}	3	1	Programmable 4500VA, 1 phase (includes three AST1501A1)	3U
AST1002A2 ^{3,4}	2	2	Programmable 1000VA, 2 Phase (Split-Phase) (includes two AST0501A1)	2U
AST1502A2 ^{3,4}	2	2	Programmable 1500VA, 2 Phase (Split-Phase) (includes two AST0751A1)	2U
AST3002A2 ^{3,4}	2	2	Programmable 3000VA, 2 Phase (Split-Phase) (includes two AST1501A1)	2U
AST1503A3 ^{3,4}	3	3	Programmable 1500VA, 3 phase (includes three AST0501A1)	3U
AST2253A3 ^{3,4}	3	3	Programmable 2250VA, 3 phase (includes three AST0751A1)	3U
AST4503A3 ^{3,4}	3	3	Programmable 4500VA, 3 phase (includes three AST1501A1)	3U
Consult Factory for higher power and/or additional phase configurations				
¹ ATE version Single Phase Multi-Chassis Packages include all ATE version chassis. One Parallel Communication System Interface Cable (PN: 890-010-26) is included for each non-master chassis.				
² Enhanced version Single Phase Multi-Chassis Packages include one Enhanced version chassis as the master. The remaining chassis are ATE version. One Parallel Communications System Interface Cable (PN: 890-010-26) is included for each non-master chassis. For all Enhanced version chassis see "MB" option.				
³ ATE version Two and Three Phase Multi-Chassis Packages include all ATE version chassis with LKM option on the master unit and LKS option on the remaining chassis. Required Clock & Lock BNC cables and BNC Tees are included. NOTE: Requires direct programming over individual LAN (LXI) or GPIB connection for each chassis/phase. This configuration is not supported in Virtual Panels Software.				
⁴ Enhanced version Two and Three Phase Multi-Chassis Packages include all Enhanced version chassis with LKM option on the master chassis and LKS option on the remaining chassis. Required Clock & Lock BNC cables and BNC Tees are included. NOTE: Requires direct programming from individual front panel or over individual LAN (LXI) or GPIB connection for each chassis/phase. This configuration is not supported in Virtual Panels Software.				
Options & Accessories				
AVIONICS Avionics options are available on Single Phase Configurations Only				
NONE				
B787 (-MC*)	Avionics Electrical Power Quality Test Software - Boeing 787B3-0147 A/B/C (B787)			
AMD (-MC*)	Avionics Electrical Power Quality Test Software - Airbus AMD24 C (A400M)			
B787 & AMD (-MC*)	Avionics Electrical Power Quality Test Software - B787 & AMD			
AVSTD (-MC*)	Avionics Electrical Power Quality Test Software Package - includes 160 (RTCA/DO160 E/F/G), 704 (MIL-STD 704 A/B/C/D/E/F), ABD (Airbus ADB100.1.8 D/E), A350 (Airbus ADB100.1.8.1 B/C)			
AVALL (-MC*)	Avionics Electrical Power Quality Test Software Package - includes AVSTD, B787, AMD			
* Add "-MC" to install option(s) on all chassis in (MC) Packages)				
Frequency & Clock Lock Options				
NONE				
HF*	High Frequency up to 5,000Hz			
LF*	Limits Output Frequency to 500Hz			
FC	Limits Output Frequency Control to 0.25%			
LKM**	Clock / Lock Master	Required Clock & Lock BNC cables and BNC Tees are included		
LKS**	Clock / Lock Auxiliary	Required Clock & Lock BNC cables and BNC Tees are included		
* = Mutually Exclusive				
** = Mutually Exclusive (Only Use LKM/LKS to create multi-phase configurations. Do not connect LKM/LKS chassis outputs together to increase output current)				

Additional Options		411 & 413 options are available on Single Phase Configurations Only	
NONE			
411 (-MC*)	IEC61000-4-11 Voltage Dips and Interruptions		
413 (-MC*)	IEC61000-4-13 Interharmonics Generator		
MB	Upgrades ATE version chassis in a Multi-Chassis configuration to Enhanced version chassis		
411 & 413 (-MC*)			
MB & 411 (-MC*)	Install MB on all chassis, 411 on master only in (MC) Packages.		
MB & 413 (-MC*)	Install MB on all chassis, 413 on master only in (MC) Packages.		
MB & 411 & 413 (-MC*)	Install MB on all chassis, 411 & 413 on master only in (MC) Packages		
* Add "-MC" to install option(s) on all chassis in (MC) Packages)			

ACCESSORIES	NOTES		
5330201-01R	3	Rack Slides (1 pair)	
890-010-26		Parallel Communication System Interface Cable (36")	One required for each auxiliary chassis in a parallel configuration
250562		Clock/Lock System Multi-Phase Cable (36") & BNC Tee	Two supplied with each chassis with LKMLKS option
VPEss	1	Virtual Panels Essentials (Windows GUI software)	Download from Web Site
VPAdv	1	Virtual Panels Advanced (Windows GUI software)	Activation key to upgrade VPEss to VPAdv
AST-Z540	3, 4	ANSI Z540 Certified Calibration	
AST-17025	3, 4	ISO 17025 Certified Calibration	